

Model SM-1 AM Splatter Monitor



FEATURES

- Inexpensive means of verifying compliance to FCC emissions limits
- Easy to operate and interpret measured results
- Measurement of in-phase (I) modulation, quadrature (Q) modulation, I+Q (chopped) and external audio signals
- 450 kHz to 1800 kHz phase-locked operation with 10 kHz or optional 9 kHz channel spacing
- Quadrature modulation measurement enables transmitter adjustments for minimum IPM
- External audio input enables evaluation of audio processor's NRSC filter performance
- Portable operation from external 12 VDC supply and optional active antenna for near field signal monitoring
- Optional peak hold circuit
- Optional spectrum analyzer 300 Hz resolution bandwidth model filter assembly
- Front panel speaker and headphone jack permit audible monitoring of interference
- Adjustable alarm output permits remote control monitoring
- Rear panel in-phase and quadrature detector outputs and buffered meter output

Introduction

The Model SM-1 Splatter Monitor provides AM broadcast engineers with a means of accurately and easily measuring off-channel emissions to ensure compliance with the FCC (NRSC-2) emissions standard. Manufactured in response to the recommendations of the National Radio Systems Committee (NRSC) for AM improvement, the instrument provides many of the features of an expensive spectrum analyzer at a significantly reduced price. The Splatter Monitor measures the level of splatter or any other spurious emissions which fall between 11 kHz and 99 kHz away from both sides of the carrier. Spectral measurements are displayed in dB below the carrier on a front panel meter. In addition, a speaker, front panel headphone jack and volume control permit aural interpretation of the measured signals. The Splatter Monitor tunes from 450 to 1800 kHz in 10 kHz steps. A 9 kHz channel spacing option is also available.

The Splatter Monitor provides both fixed and portable operation. While normally installed in an equipment rack and fed with a transmitter or common point RF sample, it also operates in the field from a twelve volt DC source. An optional active antenna then provides the RF sample.

Advantages

The Splatter Monitor measures the "I" (in-phase) or the "Q" (quadrature) modulation components individually. For the first time, AM monaural stations have the ability to reduce transmitter induced incidental phase modulation (IPM) by adjusting the transmitter neutralization and tuning while viewing the IPM level on the AM Splatter Monitor. By switching between the "I" and "Q" modes, the operator can quickly ascertain whether the splatter is being caused by improperly adjusted audio processing ("I" mode) or misadjusted neutralization of the transmitter ("Q" mode).

An adjustable frequency offset permits measurement of splatter in 1 kHz steps beginning 11 kHz away from the carrier. An Offset Bandwidth selector selects a receiver model. Using this function, the engineer can determine splatter level on both sides of the carrier as selected by the offset frequency selector.

The Splatter Monitor offers four selectable bandwidths:

1. In the 0.5 kHz position, the Splatter Monitor measures spurious emissions in 1 kHz wide segments.
2. In the 3 kHz position, the Splatter Monitor responds as a typical narrow-band AM radio.
3. In the NRSC position, the monitor responds as a wide-band receiver with NRSC deemphasis.
4. An optional position exists for custom receiver models or spectral measurement models. The optional Spectrum Analyzer Model Filter Assembly provides the same spectral response as a spectrum analyzer with 300 Hz resolution bandwidth.

In addition to RF measurements, the Splatter Monitor offers an audio input port to permit evaluation of the NRSC low pass filter performance provided by the station's audio processing equipment.

Description

The Splatter Monitor is designed primarily for full time measurement of the spectrum segments between 11 kHz and 99 kHz away from both sides of the carrier. The Splatter Monitor measures splatter level and any spurious emissions which fall within this spectrum segment.

Since splatter level normally decreases with frequency away from the carrier, the Splatter Monitor measures the most important segment of spectrum associated with splatter. This same segment of spectrum is where the changes in splatter level occur. These changes are due to factors such as shifts in modulation level, changes in program material, audio processor adjustments, and tube aging. The Splatter Monitor has an alarm that may be set to detect such changes. The station can connect this alarm to their remote control system to signal the occurrence of a splatter problem.

The Splatter Monitor is normally installed at the transmitter site to continuously monitor the transmitter's output spectrum. Although the regulations regarding emission limitations require field measurement to assure compliance, the intervening elements between the transmitter's output and the far field are usually quite linear so continuous monitoring of a transmitter's output is a reasonable indication of operational compliance. The Splatter Monitor is portable and may be used for field monitoring to assess compliance of the close-in spectrum (within 100 kHz) to emission limitation rules. The unit may also be used for field monitoring in the strong signal areas of other AM stations to investigate interference complaints. For these purposes, the Splatter Monitor derives power from an automobile's cigarette lighter receptacle (+12V) and receives its RF input signal from an optional active whip antenna.

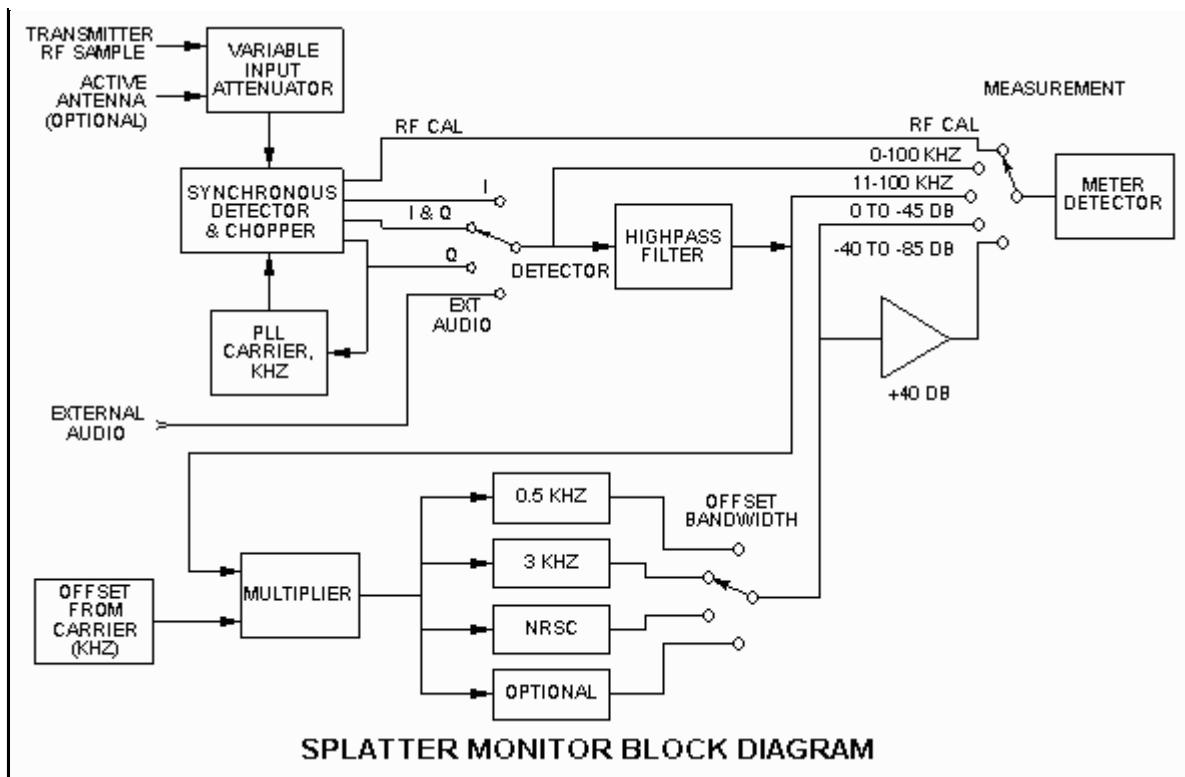

A 3-1/2 digit thumbwheel switch labeled CARRIER kHz adjusts the operating frequency of the Splatter Monitor from 450 kHz to 1800 kHz. Simple jumper changes allow operation at either 9 kHz or 10 kHz channel spacing. When tuned to 450 kHz, the Splatter monitor can be connected to the 450 kHz IF output of a synthesized receiver, taking advantage of the Splatter Monitor's synchronous detectors to evaluate the I and Q modulation of received stations.

The Splatter Monitor uses high performance in-phase and quadrature synchronous detectors. The output of each synchronous detector is available on the rear panel. When used to measure splatter, the in-phase synchronous detector measures the splatter due to distortion and clipper products and the quadrature synchronous detector measures splatter due to incidental quadrature modulation which is related to incidental phase modulation. A low frequency chopper circuit combines the I and Q components to accurately measure the overall splatter level.

The DETECTOR switch selects the in-phase detector, the quadrature detector, the chopped combination of these two detectors, or an external audio input depending upon measurement needs. The external audio input is used to analyze the audio source material fed to the transmitter's modulator.

A five position switch labeled MEASUREMENT selects the function of the Splatter Monitor. In the first switch position, the Splatter Monitor measures the DC portion of the in-phase synchronous detector for calibration of the RF input level (carrier level). The second switch position selects measurement of all signals within 99 kHz of the carrier. The demodulated signal is audible from the front panel speaker or by use of headphones. The third switch position inserts a sharp high pass filter so the meter reads the spectrum between 11 kHz and 100 kHz on either side of the carrier. This is a measure of total splatter produced by the radio station.

In the last two switch positions, the Splatter Monitor measures a selected spectrum segment of the total splatter signal in two ranges. The top meter range measures down to 45 dB below the carrier reference, and the bottom meter range measures between 40 dB and 85 dB below the carrier reference. The segment of the spectrum selected is determined by a thumbwheel switch labeled OFFSET kHz and by a bandwidth switch labeled OFFSET BW. The OFFSET BW switch selects an equivalent receiver model and the OFFSET kHz thumbwheel determines how far the equivalent receiver is tuned away from the carrier on both sides of the carrier. For spurious signal analysis, the OFFSET BW switch is set to

the 0.5 kHz position, yielding an RF bandwidth of 1 kHz which matches the step size of the OFFSET kHz thumbwheel. In the 3 kHz switch position, the Splatter Monitor responds like a typical narrow band radio. In the NRSC position, a wide band receiver is modeled with NRSC deemphasis. The switch position labeled OPTION allows selection of the optional Spectrum Analyzer Model Filter Assembly or a customer specified receiver model contained on an optional plug-in assembly.

Options and Accessories

The Model AWA-1 Active Whip Antenna is used with the Splatter Monitor to make field measurements with field strengths above 1 V/m. The AWA-1 connects to the SM-1 with a 10 foot coaxial cable which also carries DC power to the antenna. The antenna assembly magnetically mounts on a vehicle's roof.

The Peak Hold Assembly is a printed circuit assembly which mounts on the rear of the meter. When this circuit is activated, the meter displays the highest reading that occurs. When not activated, the meter displays normally varying, quasi-peak readings identical to the meter display without the Peak Hold Assembly. The Peak Hold Assembly is a factory installed option only.

The Spectrum Analyzer Model Filter Assembly is installed in the optional filter card edge connector. When the OFFSET BW switch is set to the OPTION position, the Spectrum Analyzer Model Filter Assembly is inserted in the circuit and the Splatter Monitor has the same spectral response as a spectrum analyzer set to 300 Hz resolution bandwidth. When used in conjunction with the Peak Hold Assembly, the peak readings agree closely with zero-span spectrum analyzer peak hold readings at 300 Hz resolution bandwidth. This optional filter assembly may be either factory or field installed.

The [Model SNG-1 Stereo Noise Generator](#) produces white, pink or USASI (United States of America Standards Institute) weighted, stereo noise. Seven different configurations of the left and right channel outputs are easily selected. A front panel potentiometer controls output noise amplitude, which can also be modulated by internal or external pulse sources. The SNG-1 meets the requirements of NRSC-1 (EIA-549-1988) and NRSC-2 for testing AM radio transmission facilities. These standards require a pulsed USASI weighted noise source to measure both the spectrum of the audio delivered to an AM transmitter and the RF spectrum of the transmitter output. The SNG-1 meets these requirements for both monophonic and stereophonic stations.

SPECIFICATIONS

RF Input:	50 Ohm unbalanced, 1 to 20 Vrms
Frequency Range:	450 to 1800 kHz
Lock Range:	±20 Hz above 500 kHz
Measurement Range:	0 to -85 dBc
Measurement Accuracy:	±2 dB
Detector Modes:	I (in-phase), Q (quadrature), I+Q (chopped) and external audio
Spectral Measurement Range:	11 - 99 kHz offset from carrier
Measurement	RF Cal, 0 - 100 kHz, 11 - 100 kHz, Offset Mode (0 to -45 dB and -40 to -85 dB)

Functions:

Offset Bandwidths: ±0.5 kHz Spectral Analysis Mode
 (Receiver Models) 3.0 kHz Narrow Band Receiver
 8.0 kHz NRSC Wide Band Receiver
 Optional Spectrum Analyzer Model (300 Hz resolution bandwidth) or custom receiver model.

AC Requirements: 120/240 VAC ±10%, 50/60 Hz, 10W

DC Requirements: 12 VDC, negative ground, 700 mA

Dimensions 19" wide x 5-1/4" high x 14" deep

Weight: 18 pounds

Order Numbers:

Model SM-1 Splatter Monitor, 10 kHz Channels, 120 VAC Power Supply:	915-0018-001
Model SM-1 Splatter Monitor, 10 kHz Channels, 240 VAC Power Supply:	915-0018-002
Model SM-1 Splatter Monitor, 9 kHz Channels, 120 VAC Power Supply:	915-0018-003
Model SM-1 Splatter Monitor, 9 kHz Channels, 240 VAC Power Supply:	915-0018-004
Model AWA-1 Active Whip Antenna:	940-0023-001
Model PH-1 Peak Hold Option:	940-0028-001
Model SA-1 Spectrum Analyzer Filter:	940-0029-001

For additional information on any of our products, please contact [Sales](#) to discuss your particular requirements:

Delta Electronics, Inc.
5730 General Washington Drive
P. O. Box 11268
Alexandria, VA 22312

Phone: (703) 354-3350
U.S. Toll Free: 1-800-8-DELTA-8 (1-800-833-5828)
Fax: (703) 354-0216
www.deltaelectronics.com
Email: sales@deltaelectronics.com

[HOME](#)
[AM/FM/TV Products](#)
[HF/VHF/UHF Products](#)

The Delta Electronics logo is a registered trademark of Delta Electronics, Inc.